

FertiOne™ Plus

Installation and Operation Manual

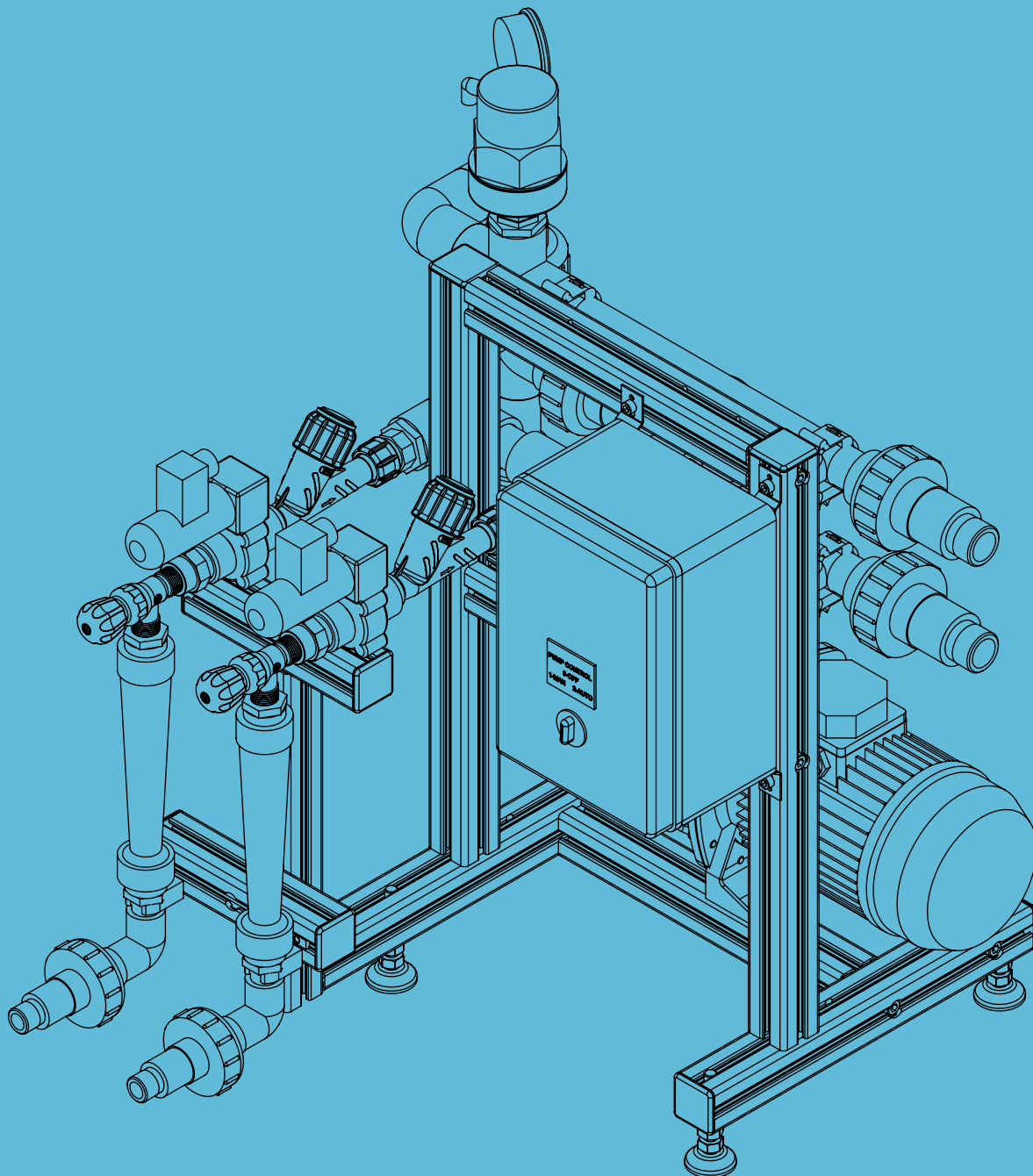

© COPYRIGHT 2020, NETAFIM™

NO PART OF THIS PUBLICATION MAY BE REPRODUCED, STORED IN AN AUTOMATED DATA FILE OR MADE PUBLIC IN ANY FORM OR BY ANY MEANS, WHETHER ELECTRONIC, MECHANICAL, BY PHOTOCOPYING, RECORDING OR IN ANY OTHER MANNER WITHOUT PRIOR WRITTEN PERMISSION OF NETAFIM™.

THIS DOCUMENT IS PRESENTED WITH THE EXCLUSIVE AIM OF NOTIFYING SELECTED POTENTIAL CLIENTS REGARDING THE NETAFIM™ FERTIONE™ PLUS. RECEIPT OR POSSESSION OF THIS DOCUMENT DOES NOT IMPLY RIGHTS AND THE CONTENTS SHOULD BE VIEWED AS A PROPOSAL ONLY. THIS DOCUMENT IS NEITHER ISSUED AS A GUARANTEE, NOR IS IT LEGALLY BINDING.

NETAFIM™ ENDEAVORS TO PROVIDE QUALITY, ACCURATE AND DETAILED INFORMATION. NEVERTHELESS, NETAFIM™ CANNOT ACCEPT ANY RESPONSIBILITY FOR RELIANCE ON THE INFORMATION PROVIDED, AND THE USER IS ADVISED TO INDEPENDENTLY OBTAIN THE PROFESSIONAL ADVICE OF NETAFIM™ AND/OR ITS AUTHORIZED REPRESENTATIVES. THERE IS NO UNDERTAKING BY NETAFIM™ THAT THE PROVIDED INFORMATION OR ANY PART THEREOF IS ACCURATE, COMPLETE OR UP TO DATE.

MENTION OF THIRD-PARTY PRODUCTS IS FOR INFORMATIONAL PURPOSES ONLY AND CONSTITUTES NEITHER AN ENDORSEMENT NOR A RECOMMENDATION. NETAFIM™ DOES NOT ASSUME ANY RESPONSIBILITY WITH RESPECT TO THE USE OR THE PROVISIONS OF SUCH PRODUCTS.

NETAFIM™ WILL NOT ACCEPT RESPONSIBILITY FOR DAMAGE OR LOSS THAT MAY RESULT FROM THE USE OF NETAFIM'S PRODUCTS OR THE USE OF THIS DOCUMENT.

NETAFIM™ RESERVES THE RIGHT TO MAKE CHANGES AND IMPROVEMENTS TO ITS PRODUCTS AND/OR THE ASSOCIATED DOCUMENTATION WITHOUT PRIOR NOTICE.



FOREIGN LANGUAGES

In the event that you are reading this manual in a language other than the English language, you acknowledge and agree that the English language version shall prevail in case of inconsistency or contradiction in interpretation or translation.

CONTENTS

Use of symbols _____	4	Installation	
Preface		Unpacking and placement _____	16
Aims of this manual _____	5	Hydraulic installation _____	16
General instructions _____	5	Connection to a controller _____	17
		Electrical installation _____	17
Safety		Initial operation _____	
Safety instructions _____	6	Preparations for running the FertiOne™ Plus ____	18
When using acid/chemicals _____	6	Running the FertiOne™ Plus _____	19
Description		Calibration	
Introduction _____	7	Calculation of dosing ratio _____	20
Advantages _____	7	Commissioning _____	21
Functions _____	8	Operation and maintenance	
Operating principle _____	8	Operation _____	22
Compatibility _____	8	Maintenance _____	22
Service _____	8	Winterization _____	23
Maintenance _____	8	Troubleshooting _____	24
Fertilizer meters (optional) _____	8	Symptoms regarding a dosing channel ____	25
System and setup illustration _____	9	Switchboard warning _____	26
Dimensions _____	11	List of parts _____	27
Weights _____	11	Warranty _____	28
Installation requirements _____		Appendices	
Electrical installation _____	12	Hydraulic conditions checklist _____	29
Flow rate stability _____	12	Pump switchboard - electrical diagram ____	30
Source water _____	12		
Pump house requirements _____	12		
On-site preparations _____			
Hydraulic infrastructure preparation _____	13		
Electrical preparation _____	15		

USE OF SYMBOLS

The symbols used in this manual refer to the following:



WARNING

The following text contains instructions aimed at preventing bodily injury or direct damage to the crops, the FertiOne™ Plus and/or the infrastructure.



CAUTION

The following text contains instructions aimed at preventing unwanted system operation, installation or conditions that, if not followed, might void the warranty.



ATTENTION

The following text contains instructions aimed at enhancing the effective usage of the instructions in the manual.



NOTE

The following text contains instructions aimed at emphasizing a certain aspect of the operation of the system or installation.



ACID HAZARD

The following text contains instructions aimed at preventing bodily injury or direct damage to the crops, the product and/or the infrastructure in the presence of acid.



ELECTRICAL HAZARD

The following text contains instructions aimed at preventing bodily injury or direct damage to the FertiOne™ Plus and/or the infrastructure in the presence of electricity.



SAFETY FOOTWEAR

The following text contains instructions aimed at preventing foot injury.



PROTECTIVE EQUIPMENT

The following text contains instructions aimed at preventing damage to health or bodily injury in the presence of fertilizers, acid or other chemicals.



EXAMPLE

The following text provides an example to clarify the operation of settings, method of operation or installation.

The values used in the examples are hypothetical. Do not apply these values to your own situation.



TIP

The following text provides clarification, tips or useful information.

PREFACE

Aims of this manual

The aims of this manual are to provide the technician with detailed instructions for installation of the FertiOne™ Plus and to provide the user with instructions for its operation and troubleshooting.

General instructions

- Installation must be performed by authorized technicians only.
- Consult with your supervisor if problems occur during installation procedure.
- Installation should be performed on a hard, leveled floor or on a flat, hard, leveled surface.
- Do not apply force or pressure on components during the installation procedure.
- The FertiOne™ Plus Can be operated manually or fully computerized, connected to a controller.
- Verify that field components work properly.
- Make sure fertilizers and acid are on site at the time of installation.

Electricity



ATTENTION

Make sure that the FertiOne™ Plus fits the electricity voltage, phases and frequency on site.

- Ensure that a suitable electrical power supply is available in the vicinity of the installation for the FertiOne™ Plus electrical connection (see [Electrical preparation](#), page 15).
- Ensure that an electrical socket is available near the FertiOne™ Plus, for installation and service.

SAFETY

Safety instructions

- All safety regulations must be applied.
- Ensure that the installation is carried out in a manner that prevents leaks from the FertiOne™ Plus, the fertilizer/acid tank and line, the peripherals and the accessories (leaks could contaminate the environment, soil or ambient area).
- Electrical installation must be performed by an authorized electrician only.
- The electrical installation must comply with the local safety standards and regulations.
- Protection provided by the equipment is liable to be impaired if the equipment is used in a manner other than that specified by the manufacturer.



WARNING

In an agricultural environment - always wear protective footwear.



WARNING

Measures must be taken to prevent fertilizer infiltration of the water source, in order to avoid water pollution.



CAUTION

When opening or closing any manual valve, always do it gradually, to prevent damage to the system by water hammer.

Safety instructions when using acid/chemicals



ACID HAZARD

When using acid - always observe the acid manufacturer's safety instructions.



WARNING

Always use protective equipment, gloves and goggles when handling fertilizers, acid and other chemicals!



ATTENTION

When dosing acid, use a dosing channel fitted with the appropriate components according to the type and concentration of acid used*:

Type of dosing channel	Diaphragm and O-rings	For pH correction					For maintenance of drippers		
		Nitric acid (HNO ₃)	Phosphoric acid (H ₃ PO ₄)	Sulfuric acid (H ₂ SO ₄)	Potassium hydroxide (KOH)	Acetic acid (CH ₃ COOH)	Hydrochloric (HCl)	Hydrogen peroxide (H ₂ O ₂)	Chlorine (as hypochlorite)
For diluted acid	EPDM	<3%	<85%	<30%	<35%	<30%	<10%	<30%	<1%
For concentrated acid	Viton	<40%	<85%	<90%	<10%	<5%	<33%	<50%	<10%

% is by weight at 21°C (70°F)

*The table indicates the resistance of the dosing channel components to acid, and is not a recommendation to use the acids mentioned.



WARNING

Exceeding the recommended acid concentrations will damage the dosing channel.



WARNING

Substances such as chemicals for pest/disease control might be corrosive and damage the FertiOne™ Plus. When using any substance other than fertilizers or acids that do not exceed the concentrations in the table above, always observe the manufacturer's instructions for corrosivity. In case of any doubt, contact your local Netafim™ representative.

DESCRIPTION

Introduction

The FertiOne™ Plus is a plug-and-play, fully configurable, simple-to-operate two-channel fertilizer/acid dosing unit offering a perfect Nutrigation™ solution for open field sites fitted with electricity where injection of up to two fertilizer solutions is needed.

It ensures the highest efficiency with minimum investment - a highly cost-effective solution for Nutrigation™.

The FertiOne™ Plus can be connected to any 24 VAC external controller to meet a vast range of Nutrigation™ needs with higher accuracy while economizing resources (fertilizer, water and energy).

The FertiOne™ Plus accommodates two 158 GPH (600 l/h) electric dosing channels for fertilizer or diluted acid.

The FertiOne™ Plus's electrical switchboard is equipped with a three-way pump control switch:

- Auto - for operation by a controller
- Off - for safe maintenance
- Manual - for manual operation or controller bypass

Capacity range

- The FertiOne™ Plus ensures a satisfactory mixture in a vast range of flow capacities.
- Suitable for main line pressure:
 - Low pressure model (with MTX5-2 60Hz dosing booster): 30 - 50 PSI (2 - 3.5 bar)
 - High pressure model (with MTX5-3 60Hz dosing booster): 45 - 80 PSI (3 - 5.5 bar)



NOTE

The maximum sound level produced by the equipment does not exceed 70 dB.

Advantages

- A Nutrigation™ system for soil applications with minimum investment
- Efficient usage of water, fertilizers and energy
- Unrivaled range of irrigation water capacities
- Designed for any application where quantitative or proportional Nutrigation™ is required
- Highly profitable price/performance ratio
- Venturi operating principle - few moving parts
- Integrates easily into any existing irrigation system
- Precise Nutrigation™ based on a high-accuracy dosing channel
- Quick action dosing valves
- Can be operated manually or fully computerized, connected to a controller.
- Can be connected to NMC and other controllers for advanced Nutrigation™ control
- A wide variety of accessories and peripherals can be integrated into the FertiOne™ Plus to enhance its functions
- High-quality components and PVC pipe work
- Aluminum, corrosion-resistant frame with adjustable legs
- Easy to install and to maintain
- Made by Netafim™

DESCRIPTION

Functions

- Manual or controlled dosing of fertilizers/acid with source water as a homogenous nutrient solution

Operating principle

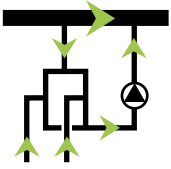

The FertiOne™ Plus doses the fertilizer or acid solution and injects it into the irrigation water main line. The suction of the fertilizers and acid in the dosing channel is based on the Venturi principle. This requires a pressure differential - supplied by the dosing booster in the FertiOne™ Plus.

The low pressure at the Venturi outlet (around 0 PSI / bars) permits the use of a high-efficiency Venturi with high suction capacity and low motive flow consumption.

Compatibility

The FertiOne™ Plus can be incorporated in any existing or planned project; in either case it offers a highly cost-effective solution for Nutrigation™.



ATTENTION

Calculations are either in US or metric units - consistency in the type of units used is essential.

Service

Servicing the FertiOne™ Plus is a prompt and simple process. The dealer keeps a small quantity of interchangeable components on hand, for replacement on site within a few minutes.

Maintenance

To prevent failures and extend the life cycle of the FertiOne™ Plus, the user must carry out regular maintenance, such as periodic rinsing of filters. For full maintenance instructions, see [Maintenance](#), page 22.

Fertilizer meters (optional)

An optional kit of 2 fertilizer meters is available (**Netafim Cat No.:** 33241-000001).

Advantages

- High level of accuracy, $\pm 2\%$.
- Only one moving part, the impeller, is in contact with the liquid for minimum wear and the utmost reliability.
- Magnetically driven sealed register is guaranteed not to accumulate moisture or fog.
- Dry contact electrical output driven by a magnetic coupling that activates a reed switch creating a pulsed output for communicating with control and monitoring equipment.
- Corrosion resistant plastic components.
- PVC body is an angle type multi-jet meter. The multi-jet design assures an equally distributed load on the impeller minimizing wear and maintaining accuracy.
- No straight pipe installation requirements.
- Easy one-step installation.

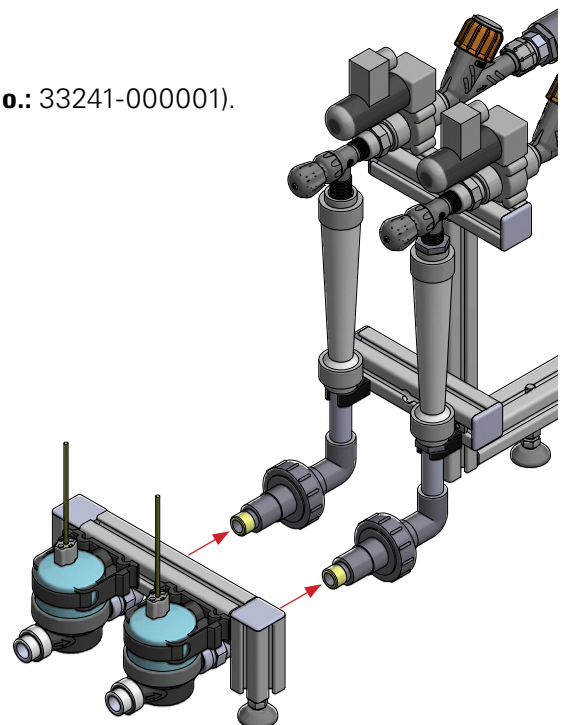

DESCRIPTION

System and setup illustration

Front view

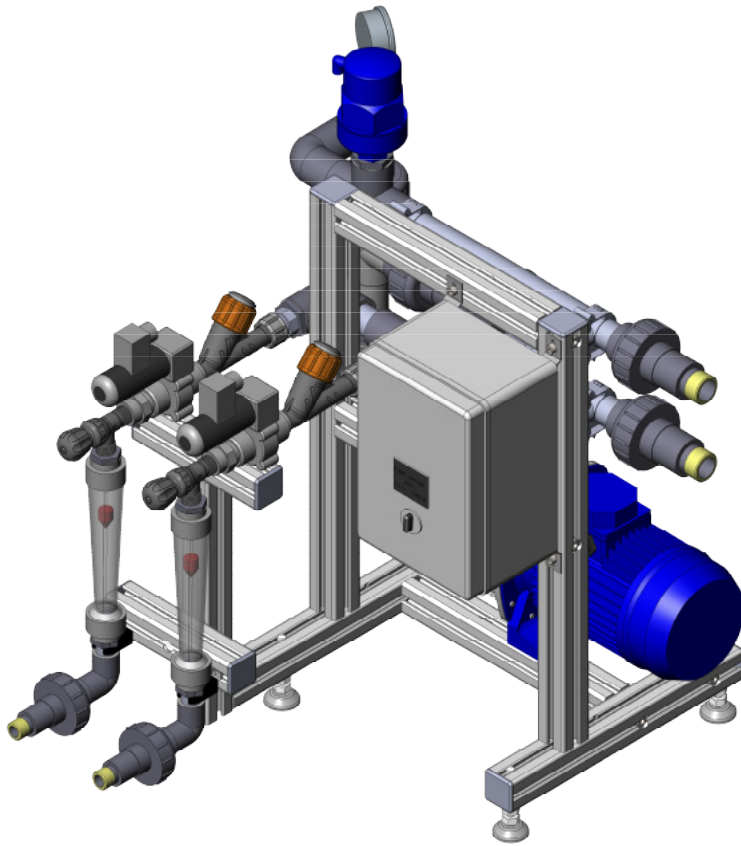

Back view

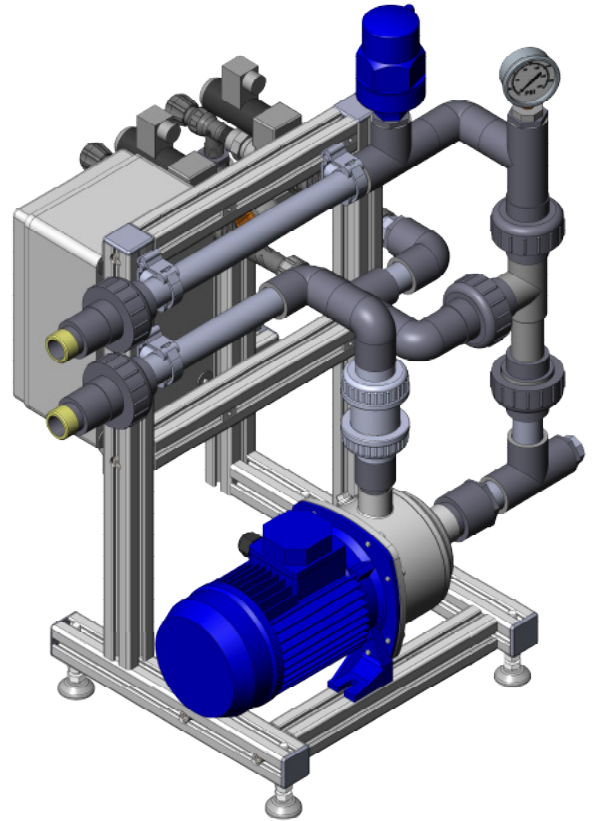

Typical setup

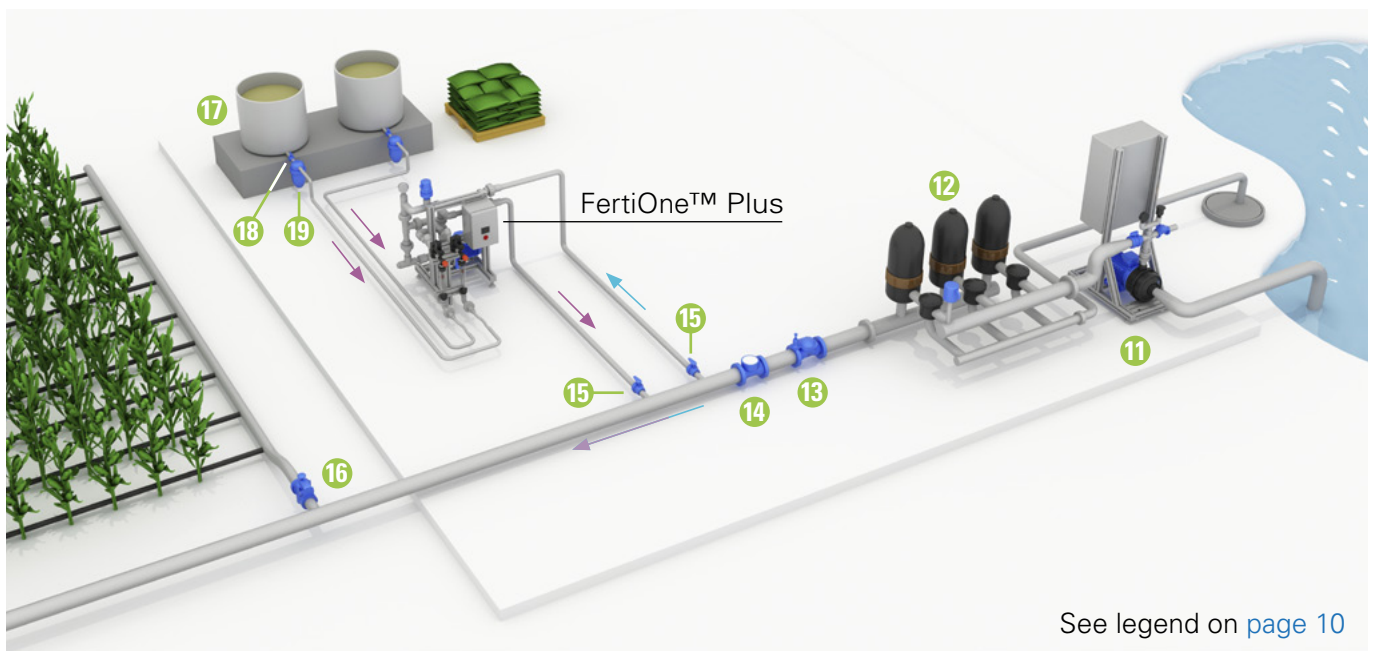

See legend on [page 10](#)

DESCRIPTION

Schematic diagram

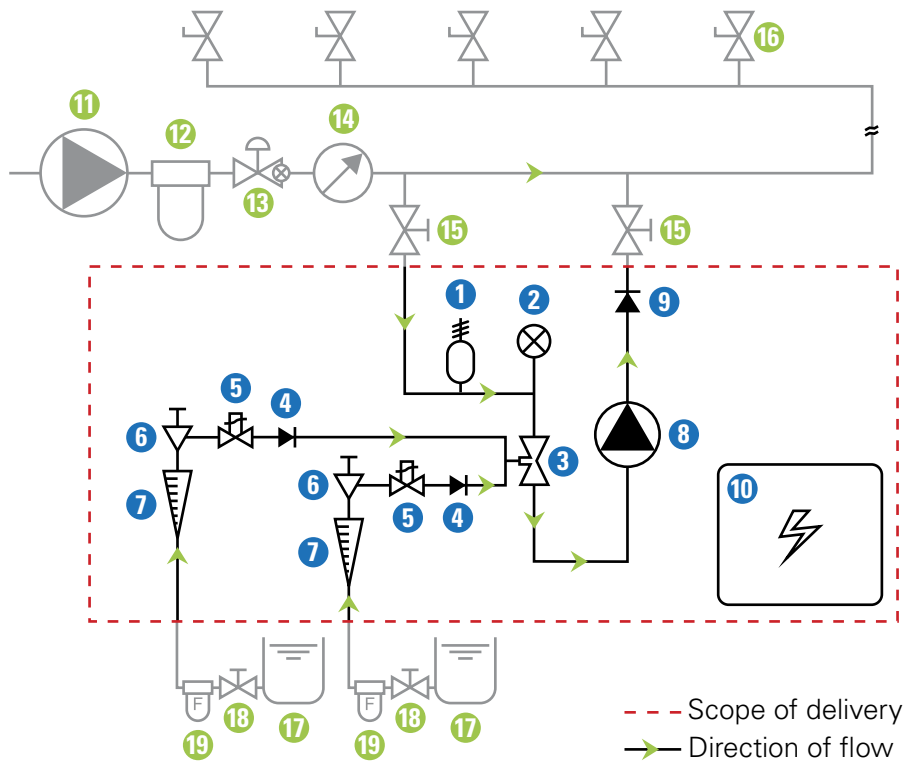

Dosing channel flow scheme

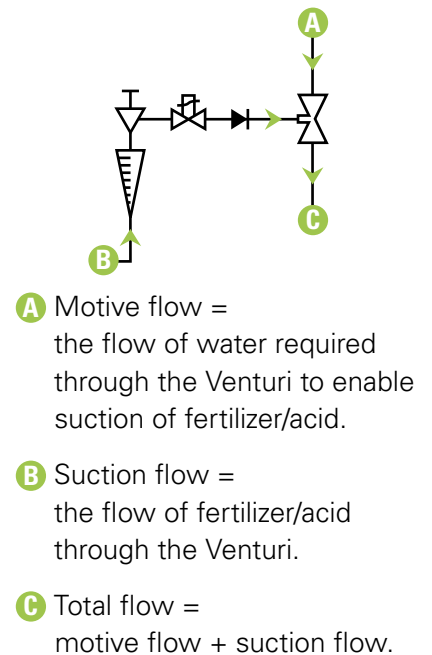

Main parts of the FertiOne™ Plus and infrastructure

The list below presents the main parts of the FertiOne™ Plus and the infrastructure parts required for its operation as depicted in the Schematic diagram above and the Typical setup drawing (page 9).

- | | |
|---------------------------------|--|
| 1 Air release valve | 11 Main line pump |
| 2 Pressure gauge | 12 Main line filter |
| 3 Venturi | 13 Main line pressure reducing valve (PRV) |
| 4 Check valve | 14 Main line water meter |
| 5 Dosing valve | 15 Manual valve (isolation) |
| 6 Needle valve | 16 Field valve |
| 7 Visual flow meter (Rotameter) | 17 Fertilizer/acid stock tank |
| 8 Dosing booster (pump) | 18 Manual valve (fertilizer) |
| 9 Check valve | 19 Fertilizer/acid filter |
| 10 Switchbox | |

Color code: ● Supplied (part of the FertiOne™ Plus) ● Not supplied (part of infrastructure)

DESCRIPTION

Dimensions

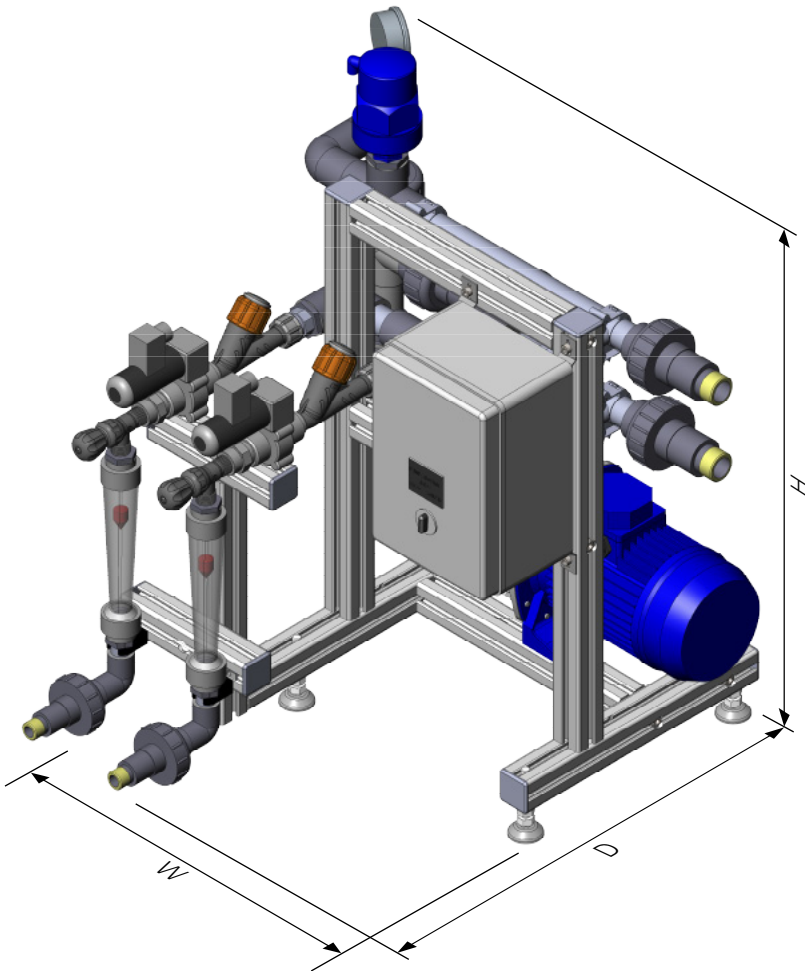

Configuration	FertiOne™ Plus external dimensions (W/D/H*)	Package dimensions (W/D/H**)
Without controller	24/26.1/29.8" (60/66.3/75.8 cm)	26.5/25/39" (67/63/99 cm)

*The height varies by $\pm 0.5"$ (± 1 cm) according to the adjustment of the legs.

**The package height includes the pallet height of 6" (15 cm).

Weights

FertiOne™ Plus maximum weight

Net weight	Packed weight
59.5 lbs. (27 kg)	92.6 lbs. (42 kg)

The weights above are order of magnitude only - final data are issued with the product order.

INSTALLATION REQUIREMENTS

Electrical installation

A 3-phase electrical supply that meets the power consumption requirements of the FertiOne™ Plus should be installed.

The electrical installation must include a circuit breaker and comply with the local safety standards and regulations.

Power consumption

- Low pressure model (with MTX5-2 60Hz dosing booster): 0.95 kW (1.28 HP)
- High pressure model (with MTX5-3 60Hz dosing booster): 1.35 kW (1.81 HP)

Flow rate stability



NOTE

To ensure flow rate stability, the consumption of the individual irrigation shifts should be as equal as possible. Each changeover between shifts with different consumption levels will result in consumption fluctuation, affecting the dosing ratio. **The consumption of the smallest shift should not be less than 75% of the consumption of the largest shift.**

Source water

- The water entering the FertiOne™ Plus should be within a temperature range of 50°F to 95°F (10°C to 35°C).
- The source water to the FertiOne™ Plus should be of a satisfactory chemical quality. If water pre-treatment is required, apply chemical conditioning before the water reaches the FertiOne™ Plus.

Pump house (Filter house / Fertilizer house) requirements



CAUTION

The FertiOne™ Plus should be:

- placed in a roofed building
- protected from direct sunlight
- kept at an ambient temperature between 50°F and 104°F (10°C and 40°C)
- kept at a maximum relative air humidity of 85%
- properly ventilated
- protected from dust
- protected from splashes or direct spraying with water or chemicals



NOTE

In order to prevent penetration of fertilizer or acid into the soil, it is recommended that the floor of the pump house have a slope of at least 1% towards a gutter at its lower edge, and an underground tank at the lower end of the gutter, enabling drainage of any spill or excess.

ON-SITE PREPARATIONS

Hydraulic infrastructure preparation

In order to enable operation of the FertiOne™ Plus, main line pressure and infrastructure conditions must be met.

Required proportions

To enable optimal operation of the FertiOne™ Plus, piping must be installed while maintaining the following proportions.

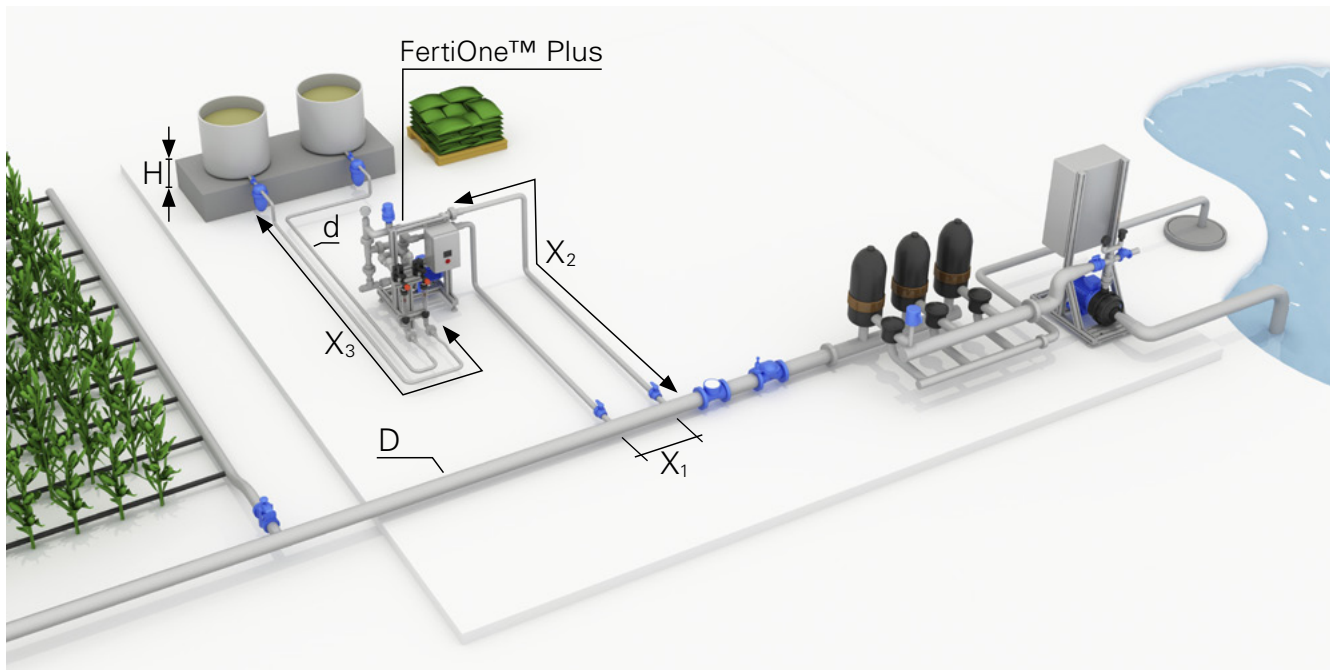

Infrastructure required proportions

Description		Required proportions
D	Main line - pipe diameter	
d	Fertilizer/acid line - pipe diameter	¾" - 1" in (25 - 32 mm)
X ₁	Distance between inlet and outlet locations on the main line	Minimum 3.3 ft (1 m)
X ₂	Length of inlet and outlet pipes	Less than 10 ft (3 m)
X ₃	Length of fertilizer or acid lines	Less than 33 ft (10 m)
H	Elevation of the fertilizer/acid tanks	Higher than 12 in (30 cm)

ON-SITE PREPARATIONS

The water distribution system

For the setup of the water distribution system, the following components should be installed.

Components of the water distribution system

Item	Specifications
15 Manual valve (isolation)	To be installed at the inlet and at the outlet of the FertiOne™ Plus, for use during system maintenance.
16 Field valve	Controllable.
14 Main line water meter	With electrical pulses. The pulse should be as short as possible according to the main line diameter and the controller's limitations. (See Recommended flow-meter pulse rate below)
12 Main line filter	≤ 130 µm (≥ 120 mesh).
11 Main line pump	Suitable for the required pressure and flow rate according to the configuration and the selected dosing booster of the FertiOne™ Plus, and the field requirements (ensure stable pressure).
13 Main line pressure reducing valve (PRV)	Should be installed on the main line, between the main line filters and the water meter and be able to reduce the main line pressure according to the field requirements.

Recommended flow-meter pulse rate for the NMC controller

Flow rate GPM	Flow-meter output US gal/pulse	Flow rate m ³ /h	Flow-meter output l/pulse
Up to 88	1	Up to 6	1
88 - 1000	10	6 - 60	10
1000-4500	100	60-600	100

The fertilizer/acid tanks and lines

For the setup of the fertilizer/acid tanks and lines, the following components should be installed:

Items of the fertilizer/acid tanks and lines

Component	Specifications
17 Fertilizer/acid stock tanks	2 fertilizer/acid solution stock tanks
18 Manual valves (fertilizer)	A manual ball valve on each fertilizer/acid line at the stock tank outlet
19 Fertilizer/acid filters	A screen filter on each fertilizer/acid line, ≥ 120 mesh (≤ 130 µm)

The following aspects should be taken into account:

- Ensure the stock tanks are of sufficient size for storage of at least one day's consumption.
- Sufficient space should be available between the fertilizer/acid tanks and the FertiOne™ Plus to enable inspection and maintenance operations.
- Fertilizer/acid pipe diameter: ¾" - 1" in (25 - 32 mm).



CAUTION

After completion of the hydraulic infrastructure, before installation of the FertiOne™ Plus, rinse the hydraulic infrastructure and fertilizer/acid lines and tanks by running water through them in order to wash away any residues (chips, shavings, sawdust) due to the setup work.

ON-SITE PREPARATIONS

Location of inlet, outlet and fertilizer/acid line connectors

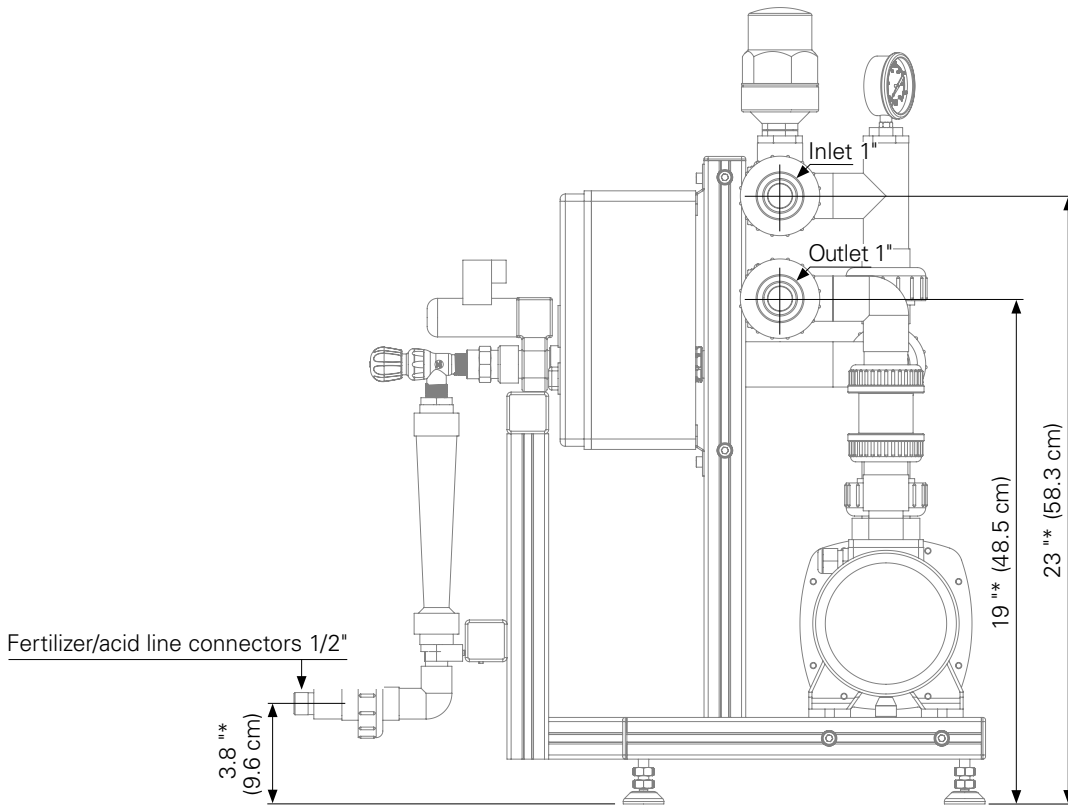

*The height may vary by $\pm 0.5"$ (± 1 cm) according to the adjustment of the legs.

Electrical preparation

Mains connection



CAUTION

Only qualified electricians are permitted to perform electrical installations!

The following components must be provided in the installation:

- A readily accessible circuit breaker, rated according to the FertiOne™ Plus's total rated power and certified as a branch circuit overcurrent protector, compliant with the national code and requirements.
- Grounding connection: $\leq 10 \Omega$.

FertiOne™ Plus's total rated power and required mains wire size

Model	Dosing booster	Voltage (V)	Current (A)	Power consumption		Mains wire size
				kW	HP	
Low pressure	MTX5-2 60Hz	3 X 440	2.2-2.2	0.95	1.28	≤ 13 awg (≥ 2.5 mm ²)
High pressure	MTX5-3 60Hz		3.3-2.9	1.35	1.81	

INSTALLATION

Unpacking and placement

Check the ShockWatch label attached to the packaging and ensure the indicator is white. If the indicator is red - follow to the instructions on the ShockWatch label.

Place the FertiOne™ Plus package close to the irrigation system.

Gently open the packaging.

Remove the screws and bolts that connect the FertiOne™ Plus to the wooden pallet.

If there is a controller, remove the plastic cover from it.

Place the FertiOne™ Plus in its position.

Adjust the legs so that the FertiOne™ Plus is steady.



Hydraulic installation



WARNING

Always use protective equipment, gloves and goggles when handling fertilizers, acid and other chemicals!

Main line inlet/outlet connection

Connect the appropriate pipes to the inlet and the outlet of the FertiOne™ Plus. see [Location of inlet, outlet and fertilizer/acid line connectors](#), page 15.

Connector

Fitting	Diameter
PVC, nipple - male NPT thread connector (supplied)	1"

Stock tank connection

Connect the fertilizer lines to the FertiOne™ Plus with 1/2" PVC pipes. See [Location of inlet, outlet and fertilizer/acid line connectors](#), page 15.

Connector

Fitting	Diameter
PVC, nipple - male NPT thread connector	1/2"



TIP

You can rotate the hose connectors of the dosing channels to face the desired direction according to the location of the stock tanks. Loosen the visual flow meter (Rotameter) lower connector **A**, rotate the hose connector to the desired direction **B** and fasten the visual flow meter (Rotameter) lower connector **A**.

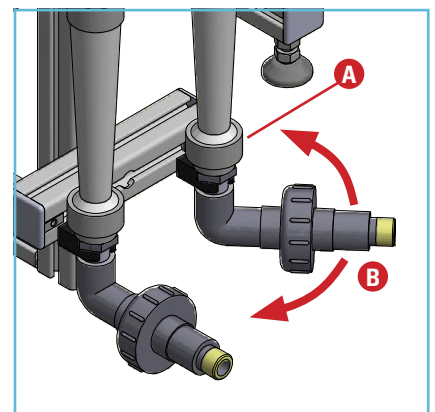

INSTALLATION

Connection to a controller

Connect the FertiOne™ Plus to the outputs of a 24 VAC controller, following the instructions on the Controller Manual.

Electrical installation



CAUTION

Only qualified electricians are permitted to perform electrical installations!

Have a qualified electrician connect the FertiOne™ Plus to the mains, following the instructions on the [Pump witchboard - electrical diagram](#) appendix, page 30.

INITIAL OPERATION



NOTE

The following procedure describes the operations that should be performed, regardless of the type of controller in use. For the operation of a specific controller interface, see the [Controller Manual](#).



ATTENTION

Make sure all the wire connectors and terminals are tightened before switching on the power!

Preparations for running the FertiOne™ Plus

For FertiOne™ Plus with a controller (onboard or external), (see the Controller Manual):

Run the controller and enter preliminary general settings.

Verify that the pressure at the pressure gauge is as required according to the main line pressure.

Connect all the elements (valves, pumps, filters, sensors, etc.) to the controller.

Manual test of controller outputs

If the FertiOne™ Plus is equipped with a controller, perform the following test to make sure that all the elements (valves, pumps, filters, etc.) function properly upon command from the controller.

Run the test using the controller's TEST menu (see the Controller Manual).

Set the relay status of the dosing channel to MANUAL and make sure that the irrigation program is not defined (see the Controller Manual).



NOTE

Make sure that the dosing valve selector is at the CLOSED position.

To check that the dosing channel is working:
Choose the OPEN command in the controller -
the LED on the dosing valve should light up.

Check for leaks



CAUTION

When opening or closing any manual valve, always do so gradually, to prevent damage to the system by water hammer.

- Make sure all the field valves are closed.
- Gradually open the isolation valves installed at the inlet and outlet of the system until the required main line pressure is attained.
Keep the system under static pressure for 10 minutes and check visually for leaks.

Check the dosing booster operation



CAUTION

If isolation valves are installed at the FertiOne™ Plus inlet and outlet, ensure that they are open before running the dosing booster.



INITIAL OPERATION

- Switch the dosing booster ON.
- Check that the dosing booster is rotating in the correct direction (see the Dosing Booster Manual).



HIGH VOLTAGE ELECTRICAL HAZARD

Before unplugging the system from the main power source, switch the unit and the main power source OFF!

Running the FertiOne™ Plus

- Define a program in the controller for one valve or multiple valves (SHIFT), as defined by the irrigation plan (see the Controller Manual).
- In the first stage it is recommended that you define a program with quantitative or proportional fertilization only (see the Controller Manual).
- Temporarily deactivate all alarms in the system - flow control, etc. (see the Controller Manual).
- Start the program and wait for the lines to be filled (this takes a few minutes, depending on the size of the installation).
- Check that the flow and the pressure on the main line are stabilized (see the Controller Manual).
- Activate the dosing booster and the dosing channel.
- Check the main line flow-meter and pressure gauge, and the pressure at the FertiOne™ Plus gauge and make sure all the hydraulic conditions are in range according to the main line pressure and flow conditions (see [Hydraulic conditions checklist](#), page 29).
- If the system cannot reach the hydraulic conditions, there might be an air pocket in the dosing booster's impeller chamber (see the Dosing Booster Manual).
- If the system still cannot reach the hydraulic conditions - loosen the dosing booster's bleeding screw and wait until a stable flow, free of air bubbles, is obtained and then retighten the bleeding screw (see the Dosing Booster Manual).
- Check the suction of the dosing channel from the stock tank, and set the desired flow rate by adjusting the needle valve.
- Let the system run for about ten minutes and see that it works properly.
- After setting the flow rate for the dosing channel, adjust the cursors on the visual flow meter (Rotameter).



NOTE

The visual flow meter (Rotameter) scale is calibrated by the manufacturer for measurement of the flow rate of water (H₂O). Certain inaccuracies may be observed when the flow rates of liquids with different densities, such as fertilizers and acids, are measured.

- Stop the program.



ATTENTION

Restore the settings of all the alarms back to the state where adequate protection of the system and the crop is provided (see the Controller Manual).

If there is any problem during the process, see [Troubleshooting](#) (page 24).

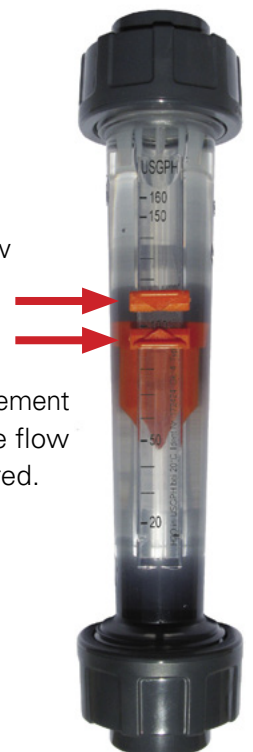

CALIBRATION

Calculation of dosing ratio

For fine calibration of the FertiOne™ Plus in order to achieve homogeneous and stable dosing, perform the following calculation to determine the amount of suction reduction needed to attain the required fertilizer/acid flow rate.

US units

Flow rate of the largest irrigation shift GPM
 X
 Dosing ratio of a single fertilizer/acid US gal/1000 US gal
 X 0.06 =
 Result: a single fertilizer/acid flow rate GPH
 X 1.25 =
 Result: target visual flow meter reading GPH

EXAMPLE

<input type="text" value="500"/>	GPM
X	
<input type="text" value="15"/>	US gal/1000 US gal
X 0.06 =	
<input type="text" value="45"/>	GPH
X 1.25 =	
<input type="text" value="56"/>	GPH

DEFINITION

Dosing ratio = $\frac{\text{The quantity of fertilizer/acid (US gal)}}{1 \text{ THG (1000 US gal) irrigation water}}$

Metric units

Flow rate of the largest irrigation shift m³/hr
 X
 Dosing ratio of a single fertilizer/acid l/m³
 =
 Result: a single fertilizer/acid flow rate l/hr
 X 1.25 =
 Result: target visual flow meter reading l/hr

EXAMPLE

<input type="text" value="120"/>	m ³ /hr
X	
<input type="text" value="3"/>	l/m ³
=	
<input type="text" value="360"/>	l/hr
X 1.25 =	
<input type="text" value="450"/>	l/hr

DEFINITION

Dosing ratio = $\frac{\text{The quantity of fertilizer/acid (l)}}{1 \text{ m}^3 \text{ irrigation water}}$



NOTE

The visual flow meter (Rotameter) scale is calibrated by the manufacturer for measurement of the flow rate of water (H₂O). Certain inaccuracies may be observed when the flow rates of liquids with different densities, such as fertilizers and acids, are measured.

COMMISSIONING

After completing the calibration process, the FertiOne™ Plus is ready for commissioning.

- Fill out the reference data line in the [Hydraulic conditions checklist](#) (page 29).

Familiarize the client with the FertiOne™ Plus, this manual (provided with the FertiOne™ Plus) and can be and the accompanying documents and emphasize the following points:

- The importance of following all the safety instructions.
- The warranty and its restrictions.
- Calibration - the user must be aware of the importance of having thorough knowledge of the calibration process for the operation of the FertiOne™ Plus.
- Proper dissolving of fertilizers for optimal utilization of the dosing channel capacity (see [Calculation of dosing ratio](#), page 20).
- The importance of regular maintenance and its impact on the warranty.
- The importance of periodic comparison of the hydraulic data with the references in the [Hydraulic conditions checklist](#) (page 29).
- Make sure the Hydraulic conditions checklist has been properly filled.
- Fill out the Commissioning Report.
- Keep both documents for future reference and send a copy of them to cmt.support@netafim.com.

OPERATION AND MAINTENANCE

Operation

The routine operation of the FertiOne™ Plus is either manual or almost totally automatic, controlled by the controller (for instructions on the operation of the controller, see the Controller Manual).

All you need is to make sure that:

- Electricity is supplied to the FertiOne™ Plus.
- Water of adequate quality is supplied at the appropriate flow rate and pressure at the inlet of the FertiOne™ Plus (see [Hydraulic conditions checklist](#), page 29).
- Properly dissolved fertilizers, according to the agronomist's instructions, are constantly present in the stock tanks.
- If acid is used - it must be constantly present in the acid stock tank and does not exceed the recommended concentration (see [Safety instructions when using acid/chemicals](#), page 6).



NOTE

When the FertiOne™ Plus is operated at a main line pressure higher than the suitable range, the suction of the Venturi gradually decreases.



WARNING

Never operate the FertiOne™ Plus at a main line pressure lower than the suitable range. There is a danger of serious damage to the dosing booster due to cavitation.*

* **Cavitation** - The formation of vapor cavities ("bubbles" or "voids") in a liquid. It usually occurs when a liquid is subjected to rapid changes of pressure that cause the formation of cavities, where the pressure is relatively low. When subjected to higher pressure, the voids implode and can generate an intense shockwave, causing significant damage to the pump's impeller and chamber.

Maintenance



CAUTION

When opening or closing any manual valve, always do so gradually, to prevent damage to the system by water hammer.

To prevent failures and extend the life cycle of the FertiOne™ Plus, be sure to carry out regular maintenance.

- Keep the FertiOne™ Plus dosing unit and its immediate environment clean and dry.
- The FertiOne™ Plus dosing unit and the supply water and irrigation system must be inspected regularly.

Regular inspection

Description	How often	Instructions
Rinsing of fertilizer filters*	Once a day	
Rinsing of supply water filters*	Once a day	
Water and fertilizer leak inspection	Once a week	Visual inspection

* Manual filters only.

OPERATION AND MAINTENANCE

Check the FertiOne™ Plus hydraulic conditions every 4 weeks

Consult the main line water meter and pressure gauge, the FertiOne™ Plus pressure gauge and the visual flow meter (Rotameter) of the dosing channel. Fill in the data on the [Hydraulic conditions checklist](#) (page 29) and make sure that all the hydraulic conditions match the reference data.

When verifying the flow rate for the dosing channel, make sure the cursors on the visual flow meter (Rotameter) are adjusted.



ATTENTION

If the FertiOne™ Plus is equipped with a controller: Once a month, read the measured flow rate of the dosing channel, compare it with the flow rate defined in the controller and check whether any changes have occurred.

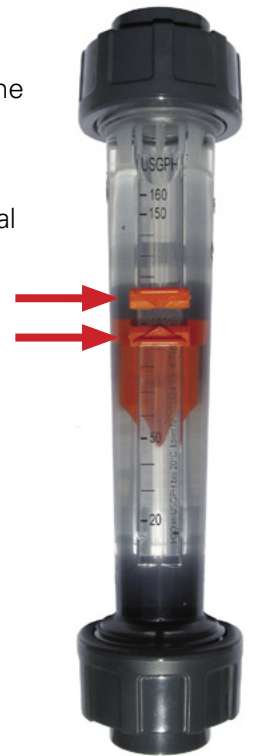

Winterization



CAUTION

When opening or closing any manual valve, always do so gradually, to prevent damage to the system by water hammer.

In areas susceptible to freezing temperatures, if the system is not required for irrigation or Nutrigation™ during the winter (mainly in open field applications), perform the following procedures to avoid damage caused by freezing when the FertiOne™ Plus is idle for the winter period:

At the beginning of winter:

- Gradually close the isolation valves and release the plug at the dosing booster inlet adaptor until the pressure in the system is released.
- Empty the FertiOne™ Plus of water by opening the plug at the dosing booster inlet adaptor.

At the end of winter:

- Close the plug at the dosing booster inlet adaptor.
- Gradually open the isolation valves until the pressure in the system is restored.

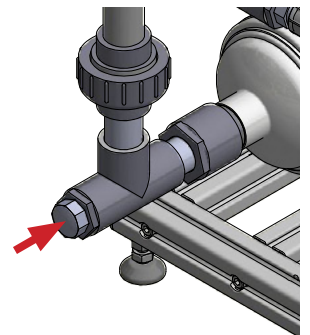

TROUBLESHOOTING

This chapter is a systematic guide to the actions to be taken in the case of a malfunction of the FertiOne™ Plus.



ATTENTION

Before proceeding to troubleshoot any malfunction, make sure that:

- The controller settings for the dosing channel are correct and match the dosing channel of the FertiOne™ Plus (see the Controller Manual).
- The controller settings regarding the field valves are correct (see the Controller Manual).

Perform the actions in their order of appearance until the malfunction is fixed.

If you identify faulty parts - consult your local Netafim™ representative.



CAUTION

Only qualified electricians are permitted to perform electrical installations and repairs!



CAUTION

If isolation valves have been installed on the system, ensure that they are in the closed position before troubleshooting any hydraulic malfunction.

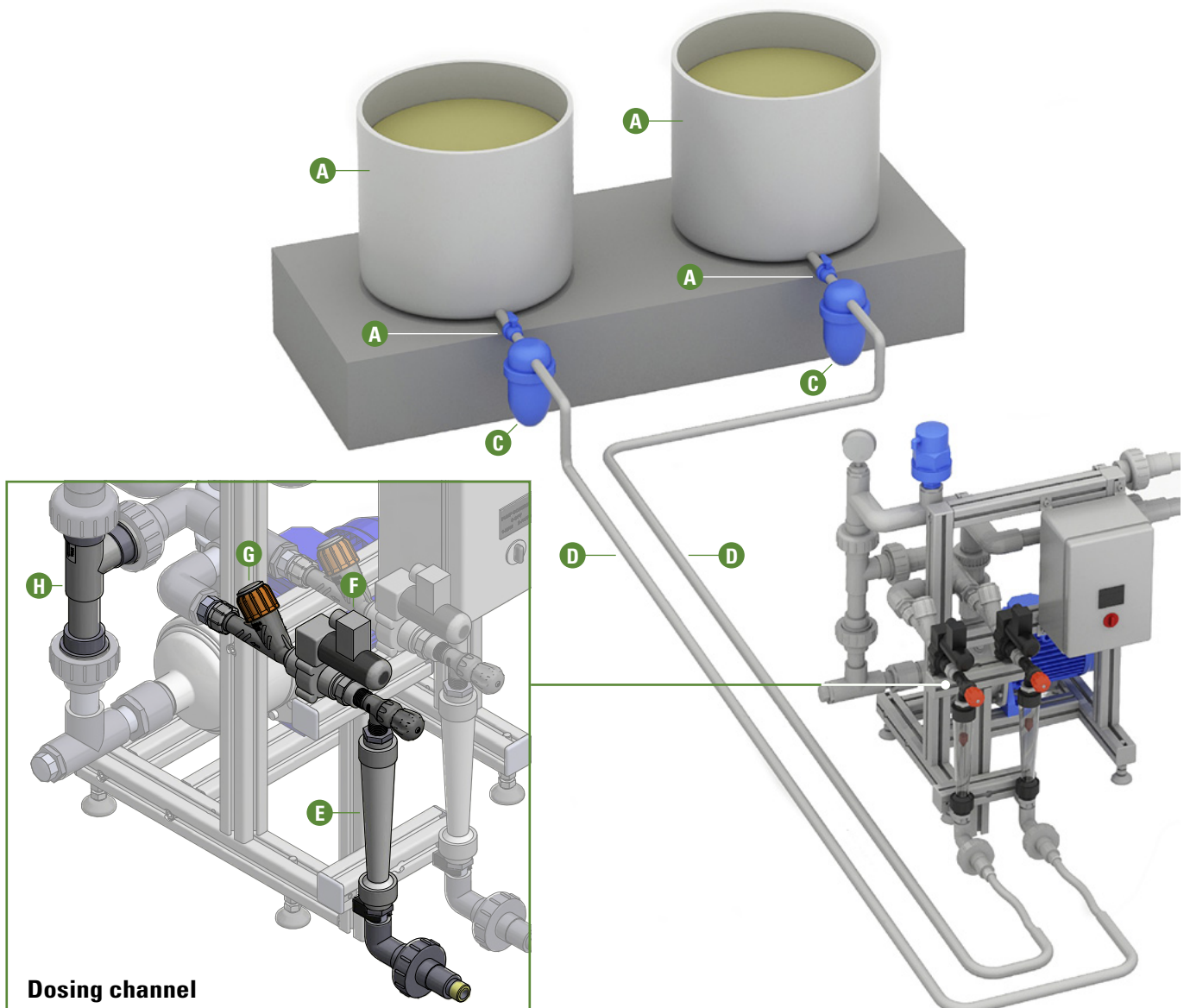

TROUBLESHOOTING

Symptoms regarding a dosing channel

If the following symptom occurs during operation, perform the actions listed below:

Visual flow meter (Rotameter) reading

- Low fertilizer/acid flow rate

Action

- 1) Check that there is fertilizer/acid solution in the stock tank **A**.
- 2) Check that the manual valve **B** of the stock tank is in the OPEN position.
- 3) Check that the fertilizer/acid filter **C** is clean - if not, it should be dismantled and thoroughly cleaned.
- 4) Check the fertilizer/acid line **D** (from the stock tank to the dosing channel) for leaks and breaches and make sure all the connectors are tightened.
- 5) Make sure the needle valve **E** of the dosing channel is open according to the reference data in the [FertiOne™ Plus Hydraulic conditions checklist](#) (page 29).
- 6) Visually check the needle valve **E** for chemical damage (internal deformation).
If internal deformation is present - replace the needle valve.
- 7) Visually check the needle valve **E** for clogging.
If clogging is present - thoroughly clean the needle valve.
- 8) If the dosing channel is equipped with an electric dosing valve, check that the dosing valve **F** is functioning:

With the controller in MANUAL mode, set the dosing valve **F** to ON (see the Controller Manual).
The LED on the dosing valve should light up.

If it does not - have a qualified electrician check the dosing valve's cable for electrical continuity.

If the cable is in working order - check the controller (see the Controller Manual).

If the controller and the cable are in working order - toggle the dosing valve **F** to OFF and again to ON in the controller (see the Controller Manual). A "click" should be heard from the dosing valve with each toggle - If a "click" is not heard, replace the dosing valve (consult your local Netafim™ representative).

If a "click" is heard and the dosing valve **F** still does not open - disconnect the dosing valve from the dosing channel, set the dosing valve to ON in the controller (see the Controller Manual) and check for clogging by injecting water at low pressure through the dosing valve.

If there is clogging - thoroughly clean the dosing valve **F** with running water.

If there is no clogging and the dosing valve **F** still does not open - replace it (consult your local Netafim™ representative).
- 9) Visually check the non-return valve **G** for any internal deformation or damage to its flat ring gasket.
If deformation or damage are present - replace the non-return valve (consult your local Netafim™ representative).
- 10) Check the non-return valve **G** for clogging by injecting water at low pressure through it according to the direction of flow.

If there is clogging - thoroughly clean the non-return valve **G** with running water.
- 11) Disconnect the Venturi **H** (top, bottom and dosing channel connections) and check it for clogging, visually and by injecting water at low pressure through it.

If there is clogging - thoroughly clean the Venturi **H** with running water.

TROUBLESHOOTING

12) Visually check the Venturi **H** for chemical damage (internal deformation).

If internal deformation is present - replace the Venturi (consult your local Netafim™ representative).

If after implementing all the above steps the malfunction is still not fixed - consult your local Netafim™ representative.

Switchboard warning



WARNING

Only authorized electricians are permitted to perform electrical repairs!

Electrical repairs must comply with the local safety standards and regulations.

If the following symptom occurs during operation, perform the actions listed below:

Switchboard ON/OFF light

- When the switchboard ON/OFF light (green) is ON it indicates that the dosing booster is ON.

If the switchboard ON/OFF light is OFF when the switch is in the ON position, proceed as follows.

Action

- 1) Check whether there is proper electricity supply:
If NO, restore the electricity supply.
- 2) Check if the circuit breaker has tripped OFF.
If YES, turn it back ON again.
- 3) If the circuit breaker trips OFF again, check that the dosing booster electricity consumption matches the data in the Dosing Booster Manual.

If after implementing all the above steps the malfunction is still not fixed - consult your local Netafim™ representative.

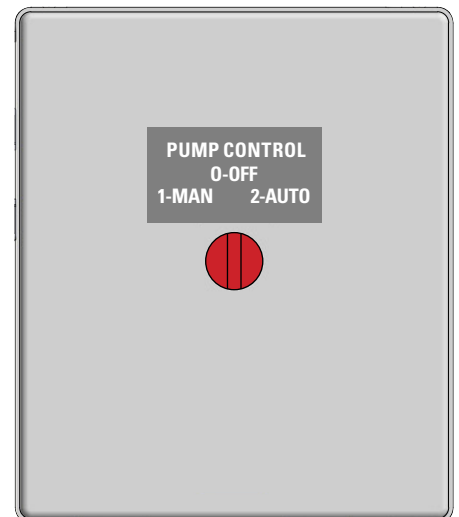

LIST OF PARTS

Part	Description	Cat. No.	
1	Aluminum frame	45000-040720	
2	Dosing booster	Low pressure model: MTX5-2 60Hz	77800-025525
		High pressure model: MTX5-3 60Hz	77800-025515
3	Switchbox	Low pressure model 60Hz	77210-003350
		High pressure model 60Hz	77210-003360
4	Inlet to dosing booster set	33241-000699	
5	Dosing booster outlet	33241-000704	
6	Suction manifold set	33241-000698	
7	Assembled dosing channel 160 GPM SCH80	33241-000705	
8	Inlet to Venturi set	33241-000697	
9	Pressure gauge 250 GLZ 10 bar (145 PSI) 1/4" BSP	77540-003400	
10	Air valve 3/4" DG-010 NPT	70561-001050	

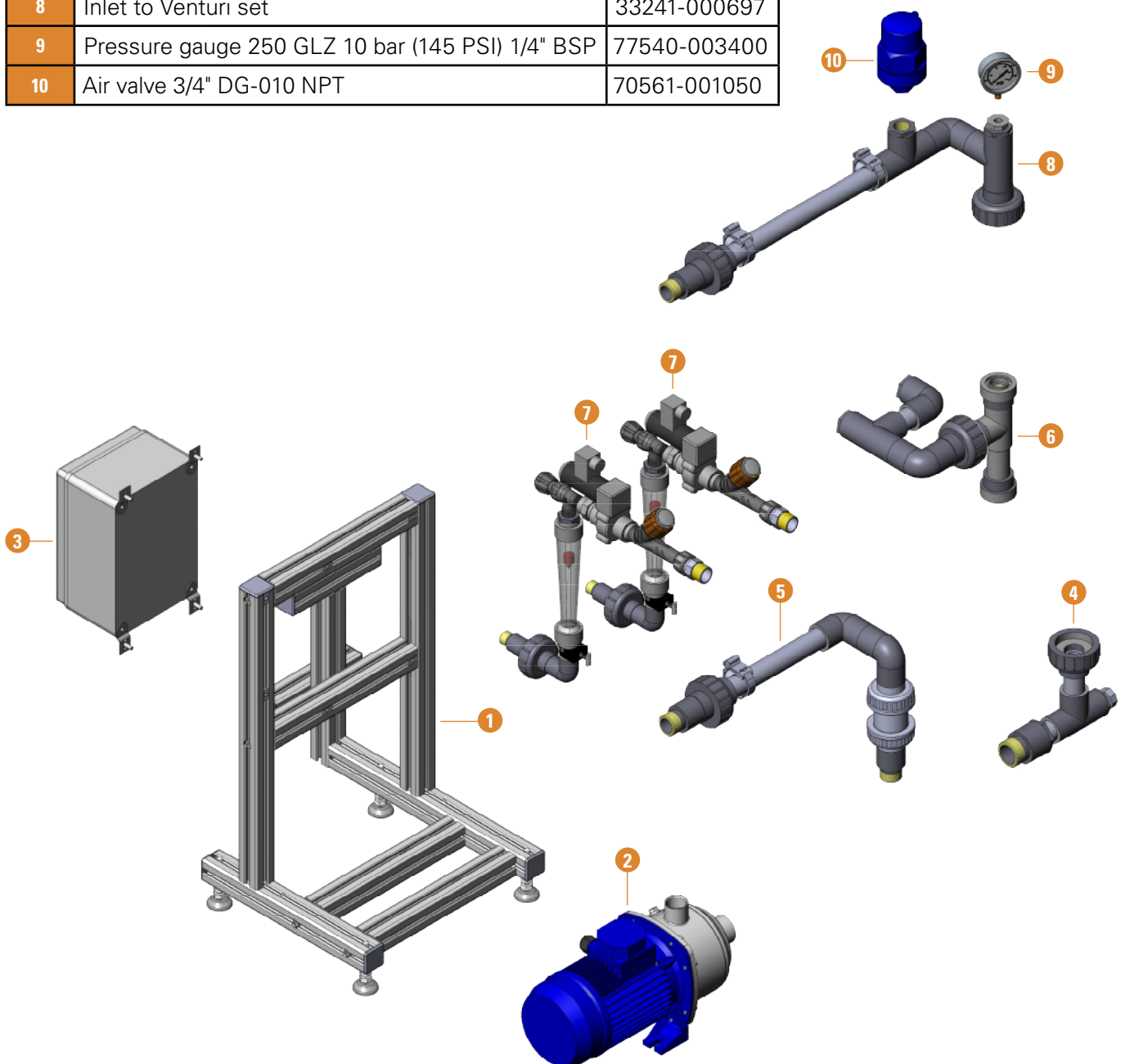

WARRANTY

Netafim™ warrants all the components of the FertiOne™ Plus to be free of defects in material and workmanship for 1 (one) year from the date of installation, provided the installation is reported to Netafim™ within 30 days of installation.

If the installation is not reported or is reported later than 30 days from the date of installation, Netafim™ will warrant the FertiOne™ Plus for a period of 18 months from the date of production, according to its serial number.

If a defect is discovered during the applicable warranty period, Netafim™ will repair or replace, at its discretion, the product or the defective part.

This warranty does not extend to repairs, adjustments or replacements of a FertiOne™ Plus or any part that results from misuse, negligence, alteration, force majeure, lightning, power surge, improper installation or improper maintenance.

If a defect arises in your Netafim™ product during the warranty period, contact your Netafim™ supplier.

Limited warranty

This warranty is subject to the conditions in Netafim's official warranty statement.
(For the full text of Netafim's official warranty statement, please contact Netafim™).

APPENDIX 2

Pump switchboard - Electrical diagram

The pump switchboard is available in 2 versions according to the FertiOne™ Plus model.

Model	Cat. No.
Low-pressure (LP)	77210-003350
High-pressure (HP)	77210-003360

Front view

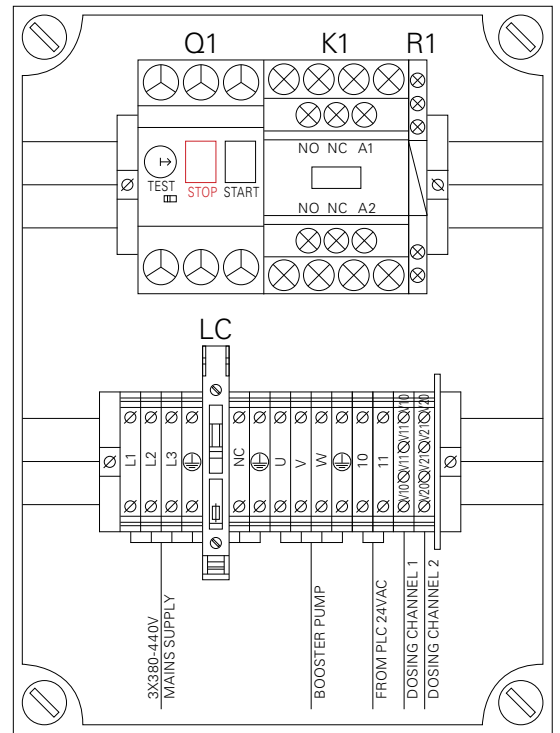

Schematic

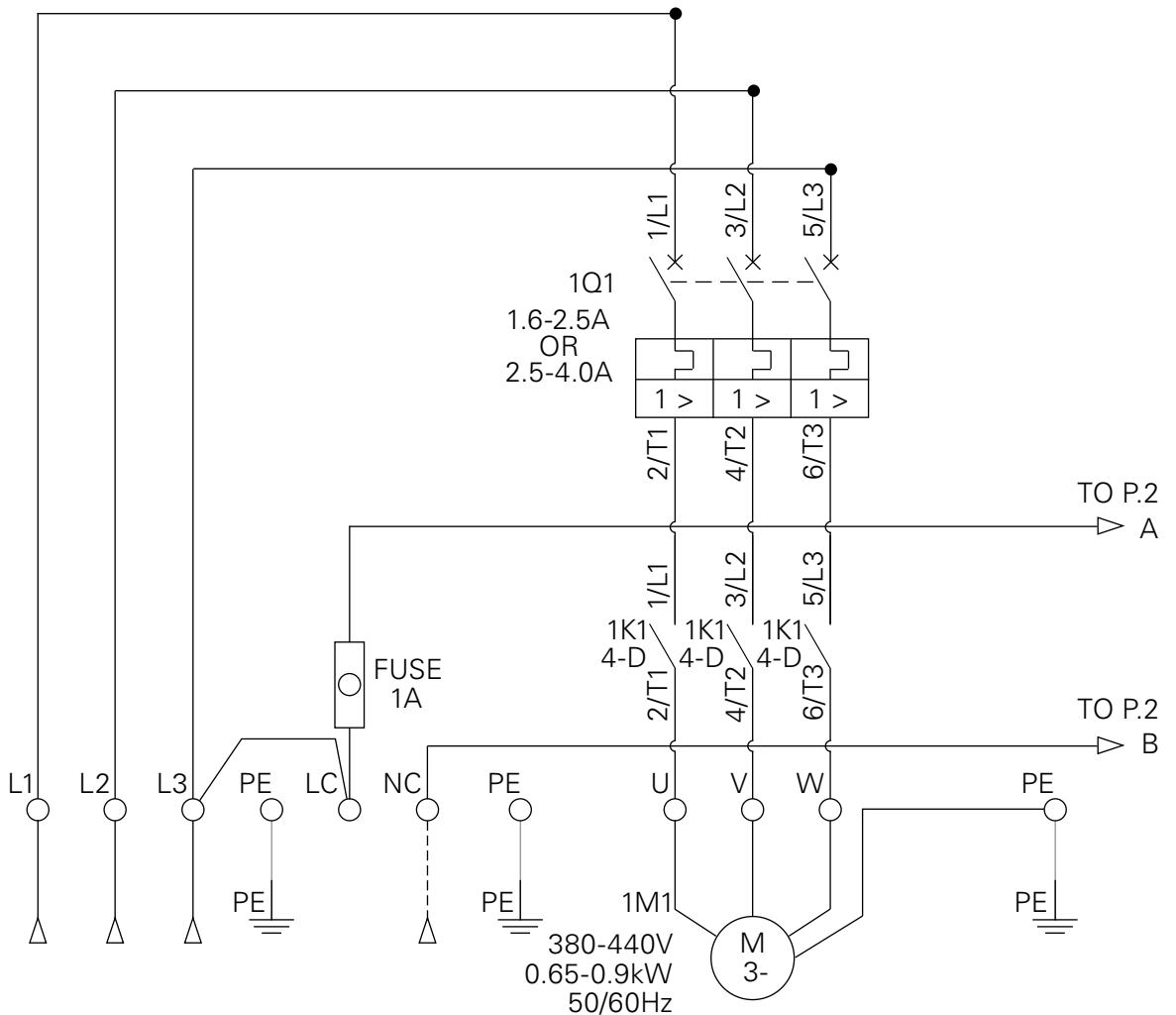

APPENDIX 2

Schematic (continued)

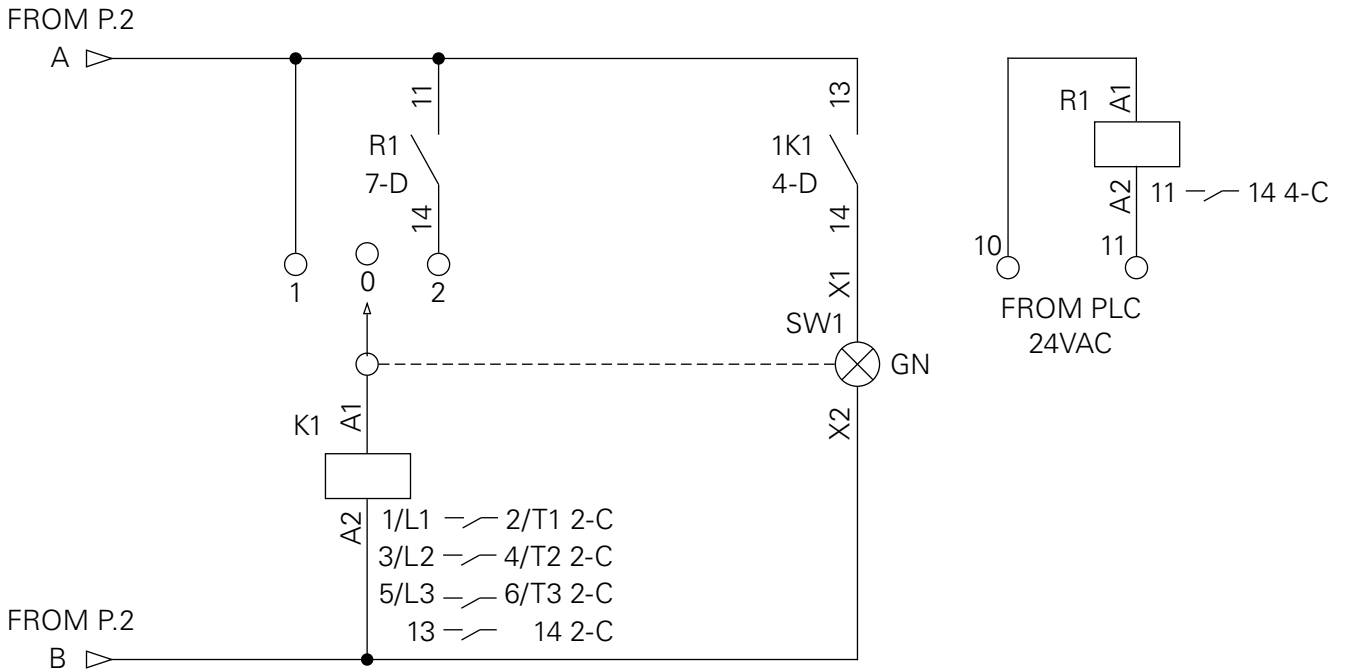

Electrical diagram components

Accessory	For model	Technical data	Type/Model	Manufacturer	Symbol
Circuit breaker	Low-pressure (LP)	1.6 - 2.5 A	GV2M07	Schneider	1Q1
	High-pressure (HP)	2.5 - 4.0 A	GV2M08	Schneider	1Q1
Contactor	Both	4kW/220-110VAC	AF09	ABB	1K1
Fuse		0.5 A	DF101	Schneider	1F1
Selector switch		+ LED 220-100VAC	SA22-AK1335	Salzer	SW1
Relay			700-HLT14 CAT 700TBR24	Allen-Bradley	R1
Box		248/174/130mm	CI	ADA	C1

GROW MORE WITH LESS

WWW.NETAFIM.COM